

## PRODUCT FEATURES



Delta Woods offers 2" slats that are hand selected from real hardwoods in both stained and painted finishes. All of Delta Woods, wood components are kiln dried to a 7% or less moisture content, which means a lighter weight blind with straighter slats. You'll notice the difference right away with the higher sheen and smoother finish. Delta Woods superior lacquer finishes are twice coated, and then oven cured for durability. Quality is prominent all the way, from the superior headrail system to the smallest detail such as ergonomically designed wood tassels.

- Trapezoid bottomrail
- Durable 2" x 2" steel headrail
- Heavy duty slats
- Crash proof cord lock
- Heavy-duty snap in component system
- Slats, valances, and bottomrail are made from hand selected hardwoods and kiln dried for lighter weight.
- Lacquer finish is twice coated, and over coated for durability
- Lead free
- FR Certified - NFPA 701 small scale capabilities
- Limited Lifetime Warranty

## PRODUCT DRAWING

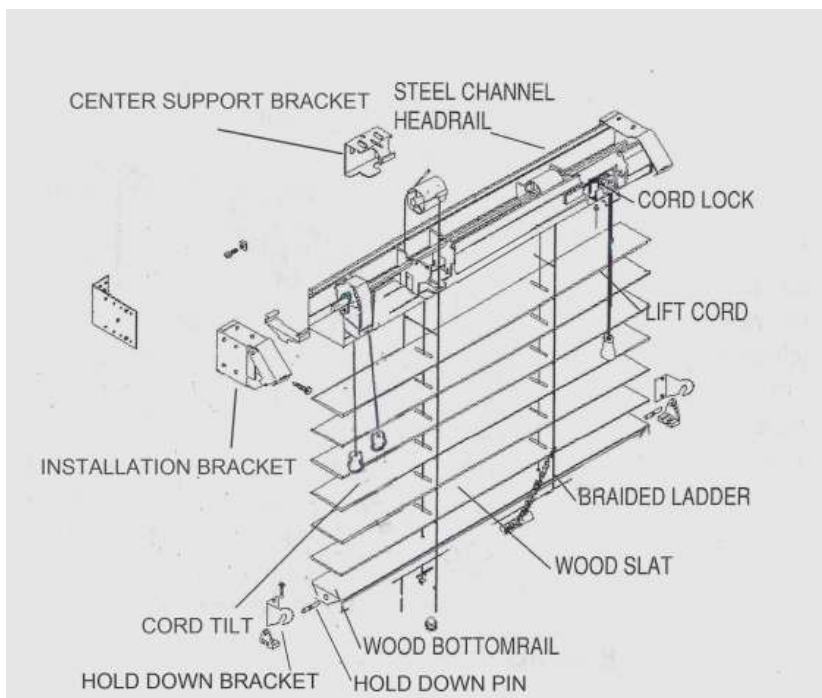

1. Center support bracket
2. Steel head rail
3. Cord lock
4. Lift cord
5. Braided Ladder
6. Slat
7. Bottom rail
8. Hold down pin
9. Hold down bracket
10. Cord tilt
11. Installation bracket
12. Installation screws



**MAG Resources, LLC**

## SPECIFICATIONS

### HEADRAIL

"U" shaped configuration: dimensions are 2" high by 2 1/4" deep, with rolled edges at the top. Fabricated steel is 0.024-inch thick (before paint) and iron phosphate treated. Head rail is acrylic primed with a finish coat of baked on polyester enamel.

a. Head rail shall incorporate color coordinated or milky white molded end caps for reinforcement.

### OPERATING HARDWARE

is of a snap in design and positioned to allow precise alignment.

### TAPE ROLL & SUPPORTS

2" Delta Woods (Braided Ladder) tape roll supports are made of low friction thermoplastic, which are self lubricating and maintenance free for smooth operation and diminished wear on lift cords and braided ladders. The support also provides the tape roll with smooth bearing points and centers it over the ladder guide hole. Tape rolls are constructed of low friction thermoplastic and designed to hold tape end by means of a "U" shaped brass grommet, which shall be inserted into tape rolls, allowing for a more precise placement of ladders when secured. As a result this gives the top slat a near level bearing position. Tape rolls shall include a projecting thermoplastic cylindrical collar integrated on each end, tilt rod is centered through both tape drum and collar projection. Self-lubricating thermoplastic collars are designed to snap securely into tape

drum supports allowing for a near effortless tilting operation. 2" Delta Woods (Cloth Tapes) tape roll supports and tape rolls are constructed of thermoplastic. Tape roll supports utilize a nylon pulley system to guide lift cords through head rail. 2" Delta Woods (Cloth Tapes) tape rolls are designed to hold cloth or vinyl tape ends firmly by means of stapled loops and provides a full tilting action.

### CORDLOCK

This component shall be a snap-in design and has a nylon roller, which the cord smoothly passes over. A secured steel roller onto a hinged lock facilitates "crash-proof" feature.

a. An optional lift cord ring pull is available in lieu of cord tassels and shall be supplied with a standard 4-inch control length.

### TILTERS

2" Delta Woods are available with either standard cord tilter or optional wand tilter. The highly accurate cord tilter utilizes a corrosion resistant steel worm and gear system, enclosed in a high impact plastic body which incorporates a spool protector that prevents the cord from slipping off of the spool. The cords operate smoothly by an incorporated pulley and cord guide. The optional wand tilter is a precise, self-lubricating thermoplastic worm and gear mechanism, with a fully enclosed plastic housing. Both precise tilter systems are designed to hold slats at any angle without movement. Color coordinated wood tassels are provided with cord tilt.

a. Optional tilt ring shall be attached to the tilter shaft in lieu of a wand, allowing for the field provision of a pole hook to operate.  
b. Optional Somfy 12 volt wire free tilt only motor, available as infrared or RTS.

### WAND

Delta Woods wands are color coordinated solid wood shafts, round in shape measuring 3/8-inch across. Wands have a maximum length of 48-inches, after which a clear plastic wand is only available. Wands attach or detach by securing wire wand segment to tilter shaft hook and sliding plastic sleeve down tilter shaft over hook.

### TILT ROD

This component, hexagonal in shape, is composed of solid galvanized steel and provides an instant tilting response. Diameter measurement across is 1 1/4".



**MAG Resources, LLC**

## SLAT

Stained wood valance, slats and bottom rail are milled from basswood, kiln dried to moisture content of 7% (+-2%). Slat material is nominally 2-inches wide and milled to a thickness of .122 (+-.0005). Contoured valance material is nominally 2.5-inches wide and milled to a thickness of 3/8-inch (+-.0005). Sculptured bottom rail is nominally 2-inches wide and milled to a thickness of 5/8-inch high. Valance, slats and bottom rail are pre-sanded, 2 coats of penetrating stain are applied and finished with 2 coats of hard lacquer on each side, then oven cured for durability.

- a. Painted wood valance, slats and bottom rail are milled from basswood. Valance, slats and bottom rails are pre-sanded then 2 coats of lacquer based paint are applied on each side and then oven cured for durability.
- b. For both stained and painted finishes, slat and bottom rail ends are color coated to match body.
- c. Optional Flame Retardant protection application is available. A certificate of validation is included that states Delta Woods with fire retardant applied meets NFPA 701 Small Scale Test Standard.

## TAPES AND LADDERS

Standard color coordinated braided ladders shall be constructed of polyester yarn with a double crossed inter-braided cable thread design, for maximum slat support and minimum stretch. Slats shall be supported by ladder tape without any visible distortion. Ladder rung distances shall not exceed 44 mm (6.9 slats per vertical foot). Distances between ladders shall not exceed 28-inches, nor distance from ladder to end of slat shall not exceed 6-inches. Optional 1.5" and 1" wide cloth tapes (in varying colors) are constructed of a high strength polyester. Spacing shall not exceed 42 mm.

- a. Braided ladder tape retainers buttons are clear thermoplastic.

## LIFT CORDS

Color coordinated lift cords shall be constructed of a braided polyester jacket with a rayon center core or approved equal. Cords shall be of sufficient length to properly facilitate the raising and lowering of blind. Diameter of cord shall be 1.8 mm (+-0.1 mm).

## END SUPPORTS

Galvanized steel installation bracket with riveted hinged cover shall be 0.038-inch thick (before paint). The outside surface has a finish coat of baked polyester enamel to color coordinate with head rail, slats and bottom rail.

- a. Intermediate support brackets are furnished for blinds 48-inches wide or as required. Maximum spacing for brackets shall be 30-inches.
- b. Optional extension brackets are available.

## PACKAGING

Corrugated 44 ECT cardboard packaging consists of 100% recycled material that is also 100% recyclable (a letter of compliance is on file for LEED qualifying projects).

## GUARANTEE

Signature Series/ 2" Delta Woods shall be manufactured exempt of any sharp edges burrs or other defects. CACO Inc. will extend a limited lifetime warranty on 2" Delta Woods head rail and components and a 5-year warranty on slats. Every horizontal blind that is properly installed is guaranteed to be free from defective components for the warranty duration, as long as the blind remain in the same window as originally installed. This obligation is limited to repair and replacement of components found defective.



**MAG Resources, LLC**