

DATA SHEET

Product Features

BALI® CLASSICS™ MINI BLINDS

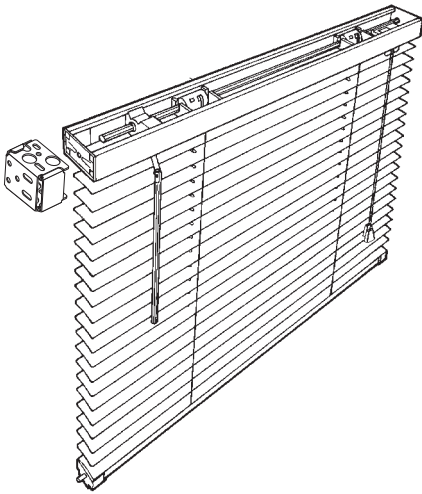

- 1" x 1-1/2" steel headrail
- AFT delivers anti-static performance to repel dust
- Low HAP, low VOC paint process
- Disengaging clutch
- Crash proof cord lock
- Enclosed bottomrail
- .006" and .008" slat option
- Perforated slat option
- Lifetime warranty

Product Specifications

BALI® CLASSICS™ MINI BLINDS

Headrail shall be 1" high x 1-1/2" wide x .025" thick U-shaped steel. The steel finishing process includes phosphate treatment for corrosion resistance, a chrome-free sealer, a low HAP urethane primer and a topcoat of low HAP polyester baked enamel.

Tilter shall be made of injection-molded thermoplastics for smooth low-friction operation and will incorporate a clutch mechanism to prevent damage due to over tilting.

Tilt rod shall be electro-zinc coated solid steel measuring 1/4" square.

Tilt wand shall be clear polycarbonate with a hexagonal cross section measuring approximately 1/4" diameter and attached to the tilter shaft by means of a spring clip for easy removal.

Cord lock shall be metal of a snap-in design incorporating a floating, shaft-type locking pin and shall incorporate a crash proof safety feature that will lock blind automatically upon release of cord.

Drum and cradles shall be low-friction thermoplastic and provided for each ladder.

Installation brackets shall be a rivet-hinged front cover phosphate-treated steel with urethane primer and polyester baked enamel finish to match headrail.

Braided ladder shall be made of 100% polyester yarn incorporating two extra strength rungs per ladder for slat support. Standard ladder spacing shall be 21.5mm.

Slats shall be 5000 series cold-rolled aluminum containing the maximum allowable recycled content to produce a high strength and corrosion resistant flexible product. Slats shall be nominally 1" wide x .006" thick and processed with Advanced Finishing Technology (AFT), providing a smooth, hard, less porous surface. AFT delivers anti-static performance to repel dust. Slats shall be treated with a topcoat of polyester baked enamel.

Bottomrail shall be completely enclosed tubular shape made of phosphate-treated steel for corrosion resistance and finished with a chrome-free sealer, low HAP urethane primer and a topcoat of low HAP polyester baked enamel and shall measure .025" thick.

Options:

- .008 slat
- 20mm ladder spacing
- 22.5mm ladder spacing
- Perforated slat (6% openness)
- Tilt limiter
- Cord tilt
- Ring tilter
- Top lock cord lock
- Ring pull
- 2 piece pocket bracket
- Turn clips for extruded pocket
- Extension brackets
- Hold down brackets
- Cut outs
- 2 slat valance
- Deluxe 2 slat valance



MAG Resources, LLC