

Graber® Lake Forest™ 2" Faux Wood Blinds

PART 1 - GENERAL

1.01 DESCRIPTION

- A. Furnish and install Graber® Horizontal Louver Blinds, provided by Springs Window Fashions LLC, 7549 Graber Road, Middleton, WI 53562 in accordance with specifications, drawings and contract documents.

1.02 SUBMITTALS

- A. Manufacturer's complete CSI 3-part specification sheet.
- B. Product Sample: Submit working hand sample or mock up blind as required.
- C. Color Sample: Submit two 6" samples of slat material indicating color and dimensions.

1.03 DELIVERY, STORAGE AND HANDLING

- A. Product to be delivered to jobsite in manufacturer's original packaging.
- B. Products to be handled and stored to prevent damage to materials, finishes and operating mechanisms. Store in a clean, dry area, laid flat to prevent sagging and twisting of packaging.

1.04 PROJECT / SITE CONDITIONS

- A. Building shall be enclosed; and windows, frames and sills shall be installed and glazed.
- B. Wet work shall be complete and dry.
- C. Ceilings, window pockets, electrical and mechanical work above window covering shall be complete.
- D. Electrical power (110 volt AC) shall be available for installer's tools within 500 feet of product installation areas.

1.05 QUALITY ASSURANCE

- A. Manufacturer, subsidiary or licensed agent shall be approved to supply the products specified and to honor any claims against product presented in accordance with warranty.
- B. Installer shall be qualified to install specified products by prior experience and approved by Springs Window Fashions LLC (SWF). Installer shall be responsible for acceptable installation in accordance with instructions published by SWF.

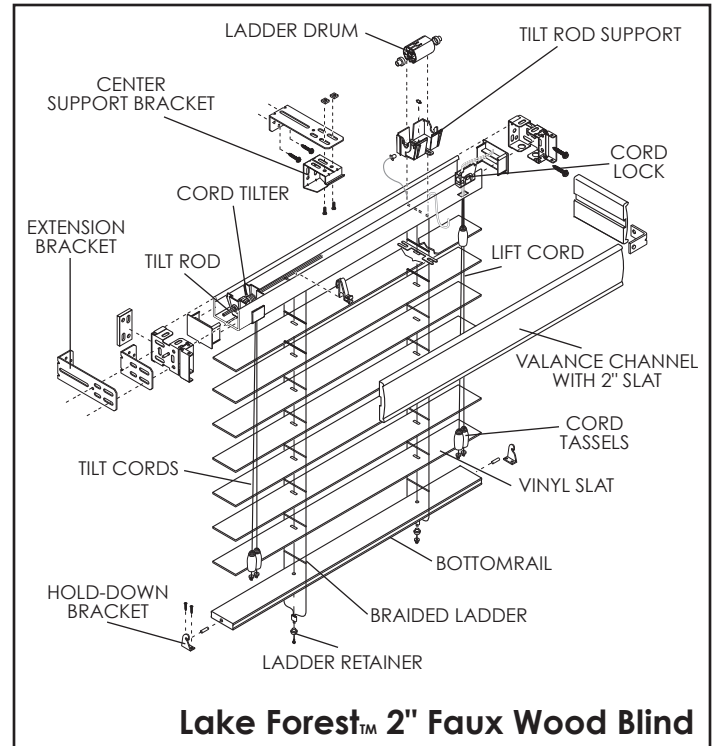

Lake Forest™ 2" Faux Wood Blind

1.06 LIMITED LIFETIME WARRANTY

- A. Springs Window Fashions LLC (SWF) warrants the product against original defects in materials or workmanship for five years. SWF does not warrant damage due to accidents, misuse, abuse, improper installation, alterations or improper cleaning. Detailed specifics of the warranty are available upon request.

PART 2 - PRODUCTS

2.01 ACCEPTABLE MANUFACTURERS

- A. Springs Window Fashions LLC or architect approved equal.
- B. Substitutions Request: Submit for approval under provisions of section 01600.

2.02 HORIZONTAL BLINDS

A. Product: Graber® Lake Forest™ Faux Wood

- a. **SureClose® Headrail** shall be 1-5/8" high x 2-1/4" wide x .022" thick U-shaped steel with 1/8" light blocking

Graber® Lake Forest™ 2" Faux Wood Blinds

- b. **Cord Tilter** shall be a snap-in component incorporating a worm and pulley of low-friction thermoplastic and nylon gear. Tilt cords shall be secured to pulley and treated with tassels at tilt end.
- c. **Tilt rod** shall be electro-zinc coated solid steel measuring 1/4" square.
- d. **Cord lock** shall be metal of a snap-in design incorporating a floating, shaft-type locking pin. Cord lock shall incorporate a crash proof safety feature that will lock blind automatically upon release of cord. End of lift cords will be treated with tassels.
- e. **Drums** shall be made of high strength thermoplastic, which securely anchors braided ladder.
- f. **Installation brackets** shall be a rivet-hinged front cover phosphate-treated steel with urethane primer and polyester baked enamel finish to match headrail.
- g. **Braided ladder** shall be made of 100% polyester incorporating two extra strength rungs per ladder to support slats. Standard ladder spacing is 44mm.
- h. **Slats** shall be rigid UV stabilized flat PVC nominally 2" wide x .10" thick with straight cut edges. Slats meet the requirement of NFPA 701 Test Method 1-2004 edition.
- i. **Bottomrail** shall be extruded foam PVC 9/16" high x 2" wide and shall coordinate with slats.
- j. **Options** shall include:
 - i. 2-1/2" slat width
 - ii. 1-1/2" cloth tape
 - iii. NoHoles™ slat
 - iv. Ring pull
 - v. Extension brackets
 - vi. Hold down brackets
 - vii. Cut outs

2.03 Fabrication

- A. Blinds shall be fabricated according to specifications and accurate to tolerance established by SWF engineering standards.

Part 3 – EXECUTION

3.01 Inspection

- A. Installer shall be responsible for inspection of jobsite, approval of mounting surfaces, verification of field measurements and installation conditions. Installation shall commence when satisfactory conditions are met.

3.02 Installation

- A. Install blinds in accordance with manufacturer's instructions including recommended support brackets and fasteners.
- B. Install blinds with adequate clearance to permit smooth operation of the blinds. Demonstrate blinds to be in smooth, uniform working order.

3.03 Maintenance and Cleaning

- A. Clean blinds with mild soap and water only. Do not use cleaning methods involving heat, bleach, abrasives, or solvents. Do not use window cloths with paper content. Use of these methods will void

