

### PART 1 - GENERAL

#### 1.01 DESCRIPTION

- A. Furnish and install Graber® Vertical Blinds, provided by Springs Window Fashions LLC, 7549 Graber Road, Middleton, WI 53562 in accordance with specifications, drawings and contract documents.

#### 1.02 SUBMITTALS

- A. Manufacturer's complete CSI 3-part specification sheet.
- B. Product Sample: Submit working hand sample or mock up blind as required.
- C. Color Sample: Submit two 6" samples of louver material indicating color and dimensions.

#### 1.03 DELIVERY, STORAGE AND HANDLING

- A. Product to be delivered to jobsite in manufacturer's original packaging.
- B. Products to be handled and stored to prevent damage to materials, finishes and operating mechanisms. Store in a clean, dry area, laid flat to prevent sagging and twisting of packaging.

#### 1.04 PROJECT / SITE CONDITIONS

- A. Building shall be enclosed; and windows, frames and sills shall be installed and glazed.
- B. Wet work shall be complete and dry.
- C. Ceilings, window pockets, electrical and mechanical work above window covering shall be complete.
- D. Electrical power (110 volt AC) shall be available for installer's tools within 500 feet of product installation areas.

#### 1.05 QUALITY ASSURANCE

- A. Manufacturer, subsidiary or licensed agent shall be approved to supply the products specified and to honor any claims against product presented in accordance with warranty.
- B. Installer shall be qualified to install specified products by prior experience and approved by Springs Window Fashions LLC (SWF). Installer shall be responsible for acceptable installation in accordance with instructions published by SWF.

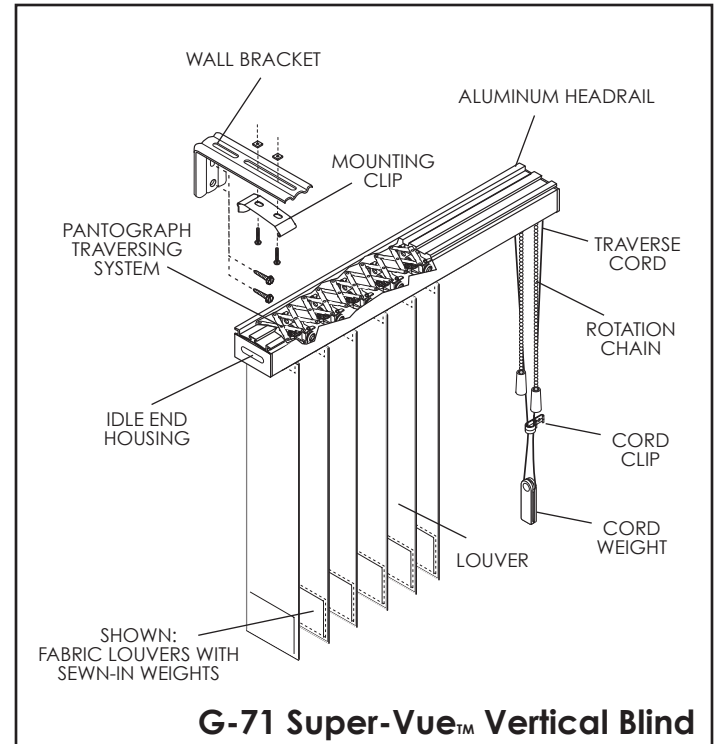

#### 1.06 LIMITED LIFETIME WARRANTY

- A. Springs Window Fashions LLC (SWF) warrants the headrail against original defects in materials or workmanship for the life of the blind and the louvers for three years. SWF does not warrant damage due to accidents, misuse, abuse, improper installation, alterations or improper cleaning. Detailed specifics of the warranty are available upon request.

### PART 2 - PRODUCTS

#### 2.01 ACCEPTABLE MANUFACTURERS

- A. Springs Window Fashions LLC or architect approved equal.
- B. Substitutions Request: Submit for approval under provisions of section 01600.

#### 2.02 VERTICAL BLINDS

##### A. Product: Graber® G-71 Super-Vue™ Vertical Blinds

- a. **Headrail** shall measure 1-15/16" wide x 1-3/8" high with an average wall thickness of .050" and made of anodized aluminum alloy 6063-T5 with a satin finish.

- b. **Carriers** shall be made of molded acetyl and traverse on self-lubricated wheels for smooth operation. Carriers shall be centrally located making the headrail reversible. Stems shall be made of clear, non-yellowing, UV-stabilized nylon and are impact-resistant. Carriers and stems shall be replaceable without demounting the headrail.
- c. **Rotation control** shall consist of #10 nickel-plated steel bead chain and a dual rack and pinion gear system providing 180° direct rotation. The pinion rod shall be extruded aluminum 0.30" diameter. Standard E-Z Open™ feature will automatically rotate louvers to the open position when the traverse cord is operated.
- e. **Traversing control** shall be a pantograph system made of hard-tempered, 18 gauge (0.046") plated steel, ensuring precise and proportional louver spacing. Traverse cord is #3 braided polyester with a fiberglass core, 0.094" diameter and is equipped with a cord weight and cord clip. The cord clip is anchored to the wall or window jamb during installation in accordance with CPSC recommendations.
- f. **Installation brackets** shall be made of zinc plated, heat treated steel and provided for overhead, wall or ceiling installation per the contract documents.
- g. **Louvers** shall be selected from the Graber® line of PVC offerings in 2" or 3-1/2" widths and/or fire-rated fabrics in 3-1/2" widths. FR certifications are available upon request.
- h. **Options** shall include:
  - i. One Touch™ wand control
  - ii. Standard valance
  - iii. Stack release
  - iv. Bottom chain
  - v. Extension brackets
  - vi. Custom painted headrail
  - vii. Curved headrail
  - viii. A-Frame angle headrail
  - ix. Elbow for bays

## 2.03 Fabrication

- A. Blinds shall be fabricated according to specifications and accurate to tolerance established by SWF engineering standards.

---

## Part 3 – EXECUTION

### 3.01 Inspection

- A. Installer shall be responsible for inspection of jobsite, approval of mounting surfaces, verification of field measurements and installation conditions. Installation shall commence when satisfactory conditions are met.

### 3.02 Installation

- A. Install blinds in accordance with manufacturer's instructions including recommended support brackets and fasteners.
- B. Install blinds with adequate clearance to permit smooth operation of the blinds. Demonstrate blinds to be in smooth, uniform working order.

### 3.03 Maintenance and Cleaning

- A. Clean fabric louvers with regular dusting or vacuum with a soft brush attachment. Clean vinyl louvers by means of a mild detergent and warm water. Do not use cleaning methods involving heat, bleach, abrasives, or solvents. Use of these methods will void the warranty.

